

(2) POLYLOK 508MM (20") \varnothing RISERS & LIDS
PART No. 3009, 3009-RC

NOTE:
MATERIAL: CONCRETE 32MPa @ 28 DAYS, NON-SULFATE
AIR ENTRAINMENT: 5-7%
REINFORCEMENT: CAN/CSA-G30.18
CONSTRUCTION: MEETS CSA B66-05
TOTAL WEIGHT: 4900 kg (10,805 LBS)
TOTAL VOLUME: 4500 L
MONOLITHIC CAST CHAMBER DIVIDER
INLET/OUTLET: CAST-IN 102mm (4") \varnothing GASKETED PVC COUPLER
BAFFLE: 102MM (4") \varnothing PVC
JOINT: N/A
ASSEMBLY: AT FACTORY
MAX. BURIAL DEPTH: 1.2M (47.25")
ALL DIMENSIONS IN MM
INCHES

SPECIFICATION PLATE
LOCATION

Top view

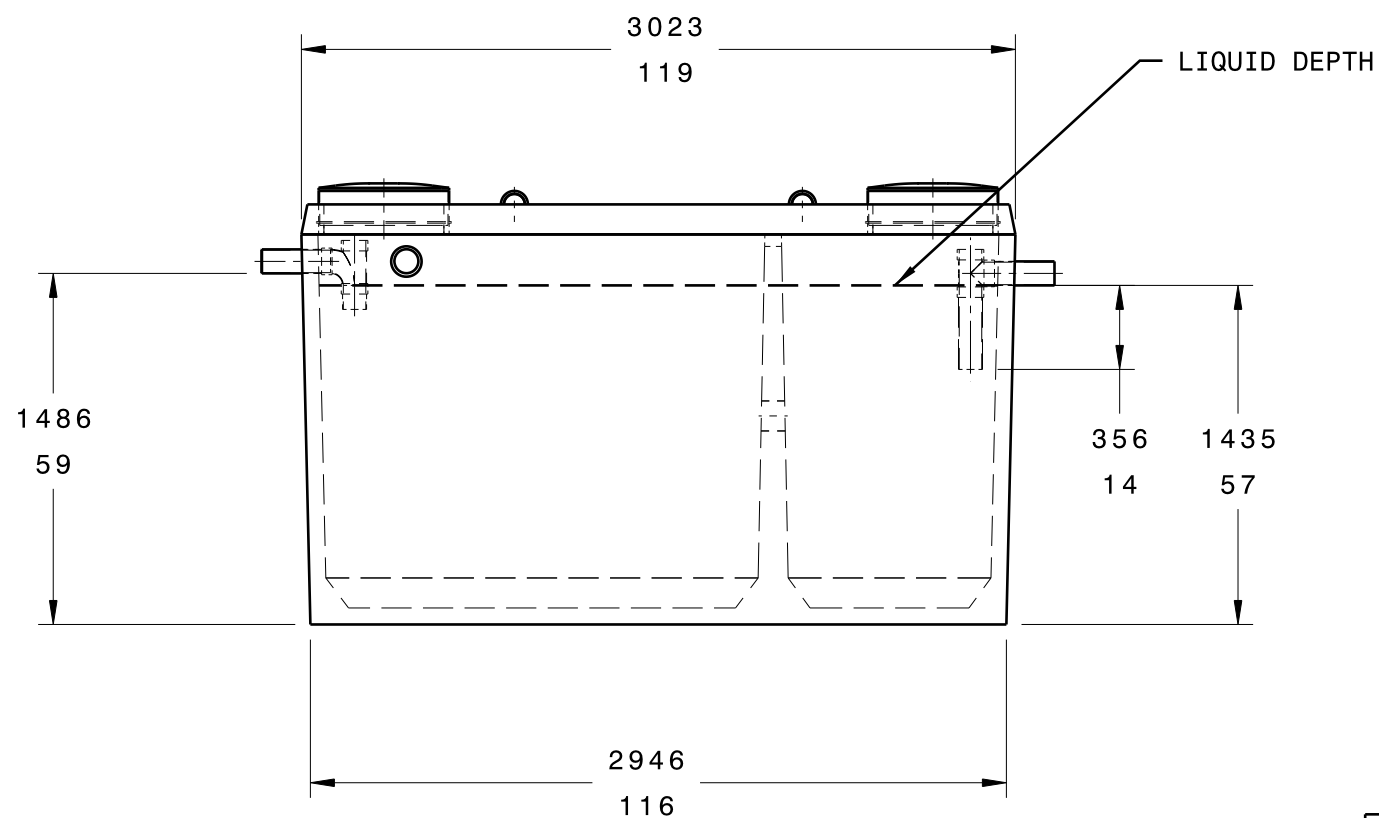

LIQUID DEPTH

Front view

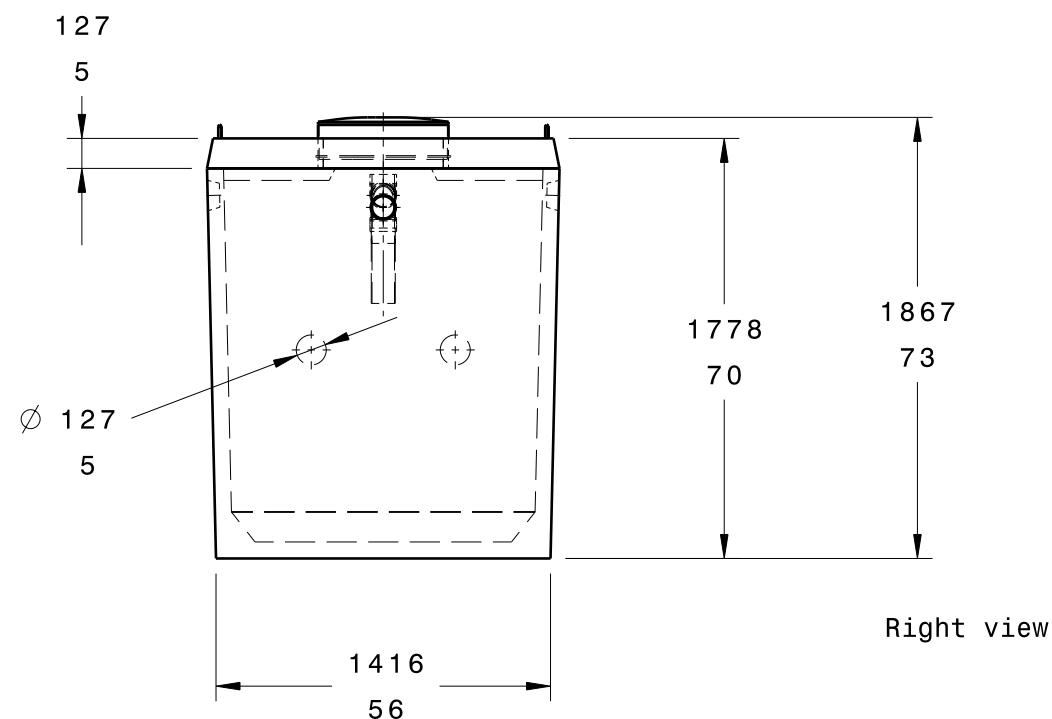

Right view

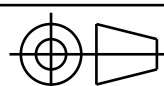
DESIGNED BY: WJ Reid		REIDS PRECAST CEMENT PRODUCTS LTD R.R. 4 LANGTON, ON NOE 1GO (519) 875-2121		I	-
DATE: 3/29/2005				H	-
CHECKED BY:				G	-
DATE:		F	-		
SIZE B		E	-		
SCALE 1:32		D	-		
WEIGHT (kg)	DRAWING NUMBER 4500T	C	-		
		B	-		
		A	-		

This drawing is our property; it can't be reproduced or communicated without our written agreement.