

(2) POLYLOK 508MM (20") Ø RISERS & LIDS  
PART No. 3009, 3009-RC

Top view

IDENTIFICATION TAG  
LOCATION

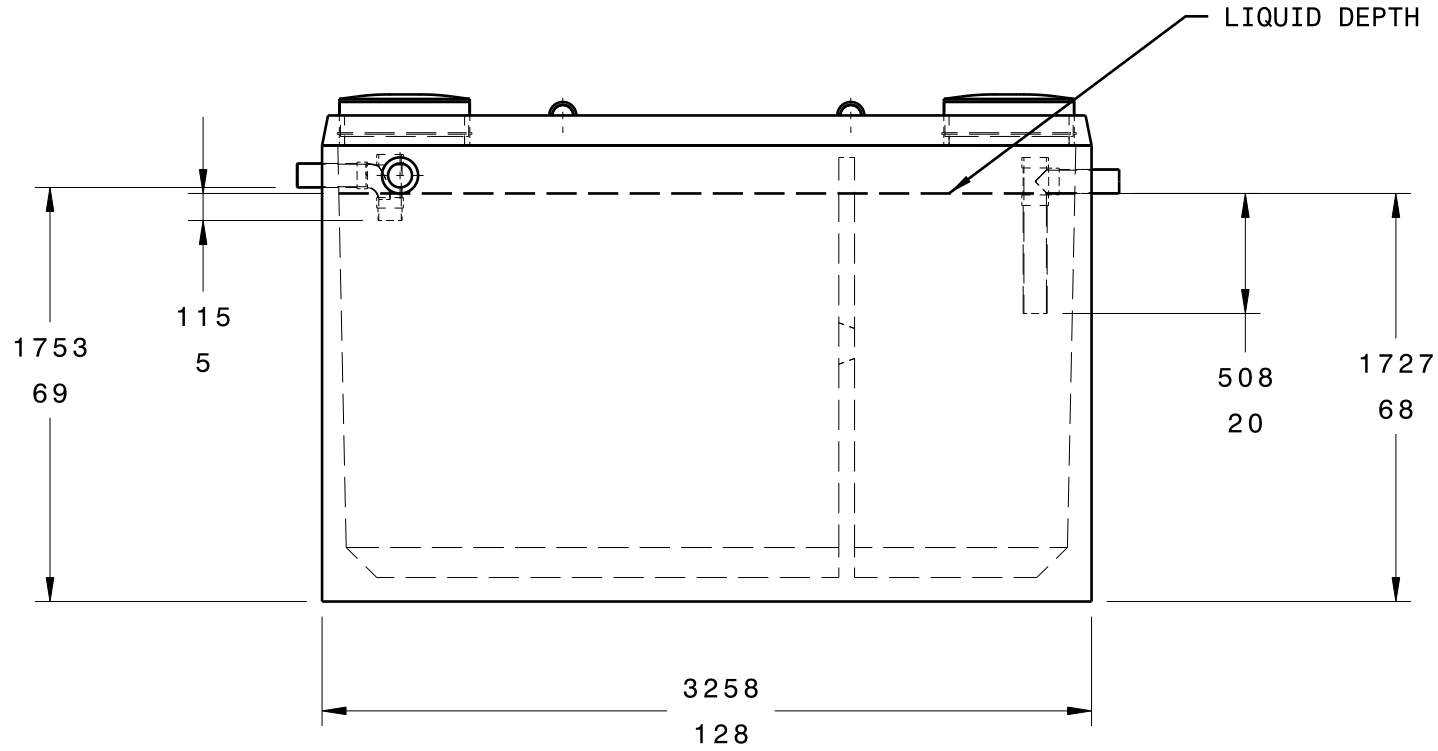

Front view

KNOCK-OUT TYPE  
AUX. INLETS (2)

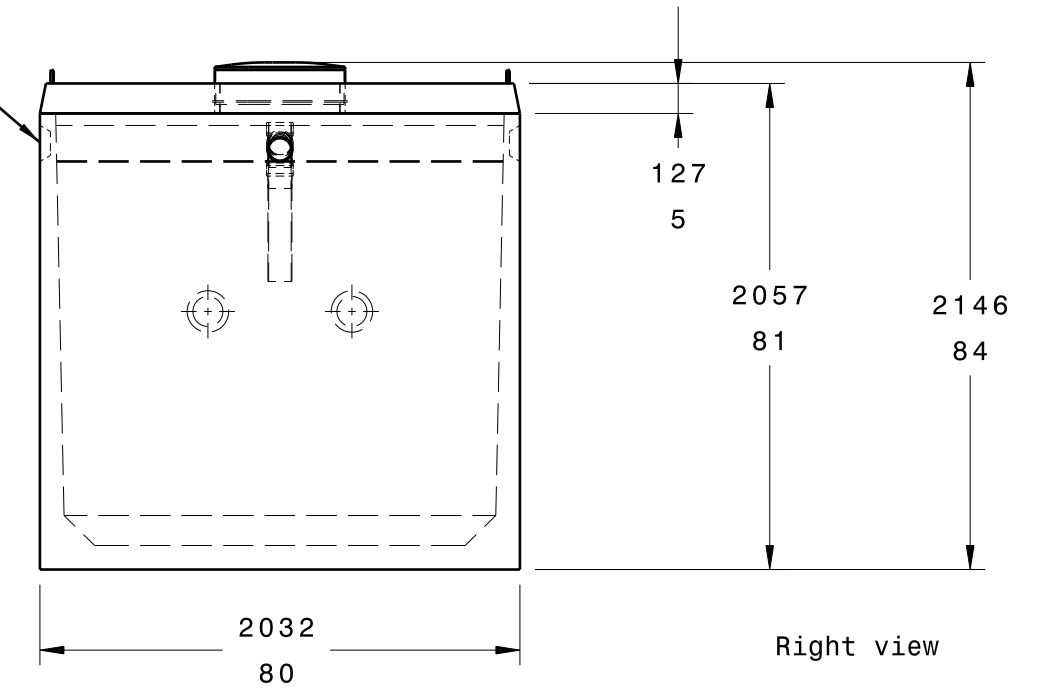

Right view

**NOTE:**  
**MATERIAL: CONCRETE 32MPa @ 28 DAYS, NON-SULFATE**  
**AIR ENTRAINMENT: 5-7%**  
**REINFORCEMENT: CAN/CSA-G30.18**  
**CONSTRUCTION: MEETS CSA B66-05**  
**TOTAL WEIGHT: 7850 kg (17,309 LBS)**  
**TOTAL VOLUME: 9025 L**  
**CHAMBER DIVIDER CAST IN A SECOND PROCESS**  
**INLET/OUTLET: CAST-IN 102mm (4") Ø GASKETED PVC COUPLER**  
**BAFFLE: 102MM (4) Ø PVC**  
**JOINT: N/A**  
**ASSEMBLY: AT FACTORY**  
**MAX. BURIAL DEPTH: 1.2M (47.25")**  
**ALL DIMENSIONS IN MM**  
**INCHES**

DESIGNED BY: WJ Reid		<b>REIDS PRECAST CEMENT PRODUCTS LTD</b> R.R. 4 LANGTON, ON NOE 1G0 (519) 875-2121		I	-
DATE: 5/29/2005				H	-
CHECKED BY:		<b>9000 LITRE (2000 IMP GAL) SEPTIC TANK</b>		G	-
DATE:				F	-
SIZE <b>B</b>		<b>9000T</b>		E	-
SCALE <b>1:32</b>	WEIGHT (kg)			D	-
DRAWING NUMBER		<b>1/1</b>		C	-
SHEET				B	-
This drawing is our property; it can't be reproduced or communicated without our written agreement.				A	-

I	-
H	-
G	-
F	-
E	-
D	-
C	-
B	-
A	-